

# Local Area Networks

What's a LAN?

A **transmission system**, usually **private** owned, very **speedy and secure**, covering a geographical area in the range of **kilometres**, comprising a **shared transmission medium** and a set of **hardware & software** for **interfacing** devices to the medium and regulating the **orderly access** to the medium. Generally it carries a great amount of the enterprise's internal communications load.

## LAN Applications

- Personal Computer & workstation LANs: cheap, limited speed & load
- Backend Networks and Storage Area Networks: separate 'one room' network, high speed, transfer of large blocks of data, for data processing or storage (inter-connecting large systems: mainframes and large storage devices)
- High-Speed Office Networks: for modern offices requiring increased processing power & speed (image & graphical processors, fax machines, local high capacity storage devices)
- Backbone LAN: high-speed LAN interconnecting various lower cost & capacity LANs spread within buildings or departments

## LAN Architecture

Described in terms of  
**Protocol architecture**

Includes:

- Physical + Topologies
- Media access control
- Logical Link Control

Comparison between OSI  
and LAN protocol stacks:

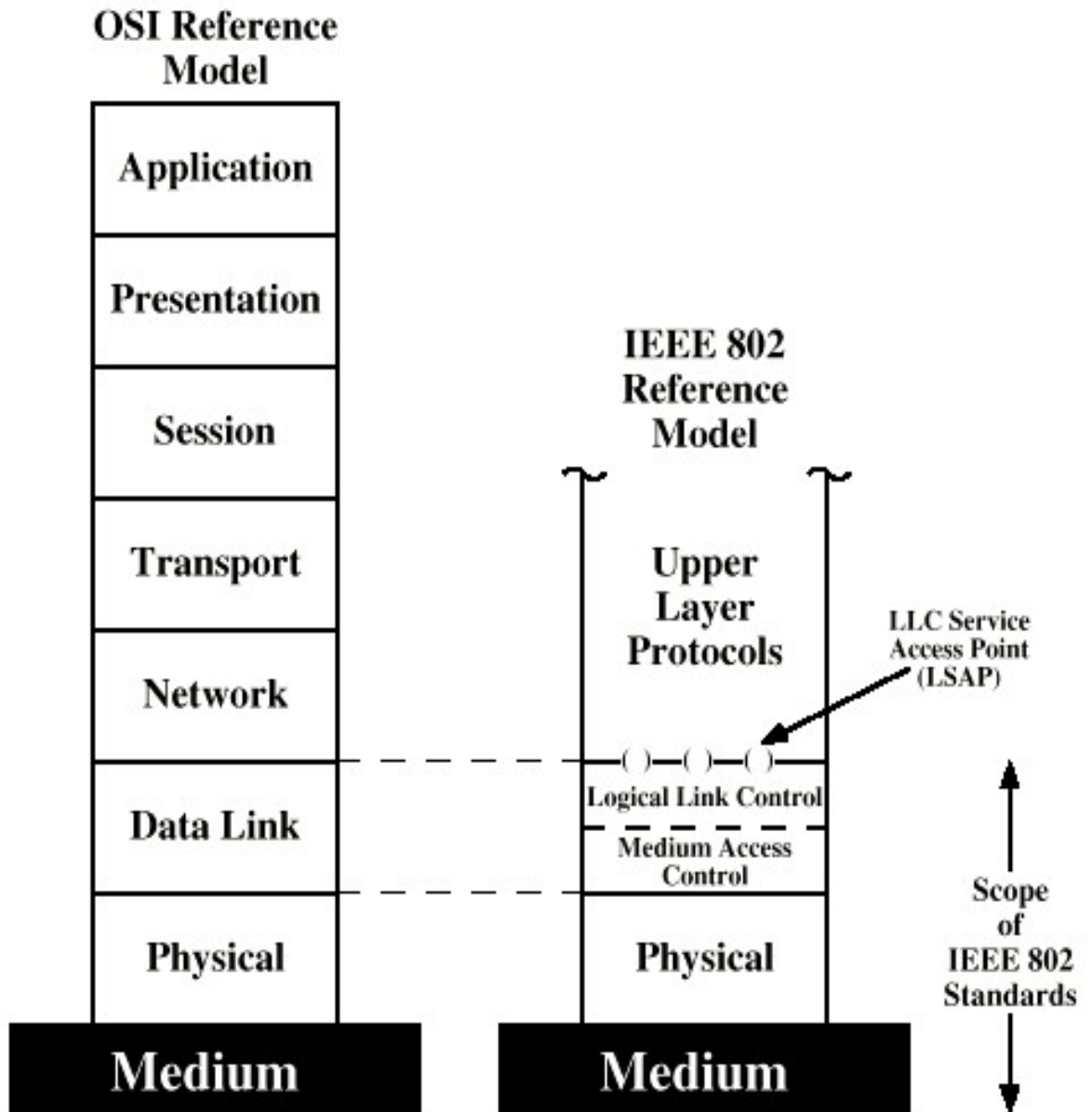

## LAN Generations

### First

CSMA/CD and Token Ring

Terminal to host and client - server

Moderate data rates (tens of Mbps)

### Second

FDDI

Backbone

High performance workstations

### Third

ATM-based

Aggregate throughput and real time support for multimedia applications

## Wireless LANs Generations

## **Third Generation LANs**

Support for multiple guaranteed classes of service

- Live video may need 2Mbps

- File transfer can use background class

Scalable throughput

- Both aggregate and per host

Facilitate LAN/WAN internetworking

## LANs Protocol Architecture

Covers lower layers of OSI  
Reference model

IEEE 802.x standard suite:

### LAN Reference model

Three layers:

- Physical
- Logical link control (LLC)
- Medium access control (MAC)

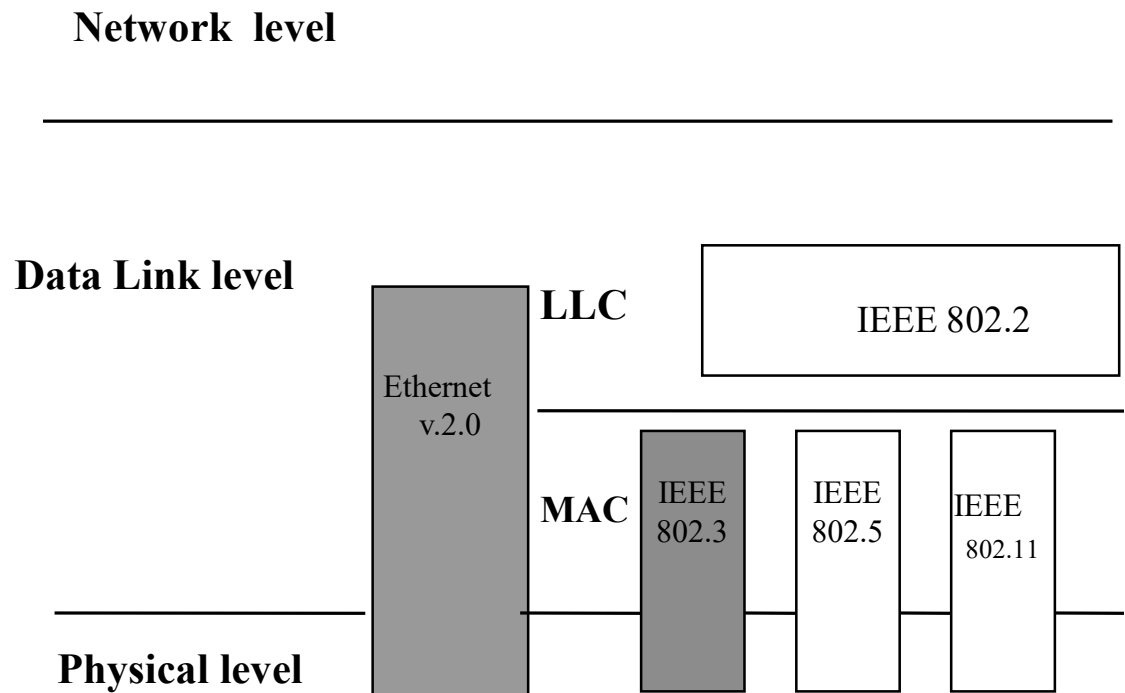

## 802.x Layers

### Physical

Encoding/decoding

Preamble generation/removal

Bit transmission/reception

Transmission medium and topology

### Logical Link Control

Interface to higher levels

Flow and error control

Several kind of services: connection oriented/connectionless

### Media Access Control (not found in traditional layer 2 Data Link control)

Assembly of data into frames, with address and error detection fields

Disassembly of frame

Address recognition

Error detection

Govern access to the transmission medium

For the same LLC, several MAC options may be available

Encapsulation of data at successive layers: how is obtained the MAC frame  
(OSI terminology: Protocol Data Unit)

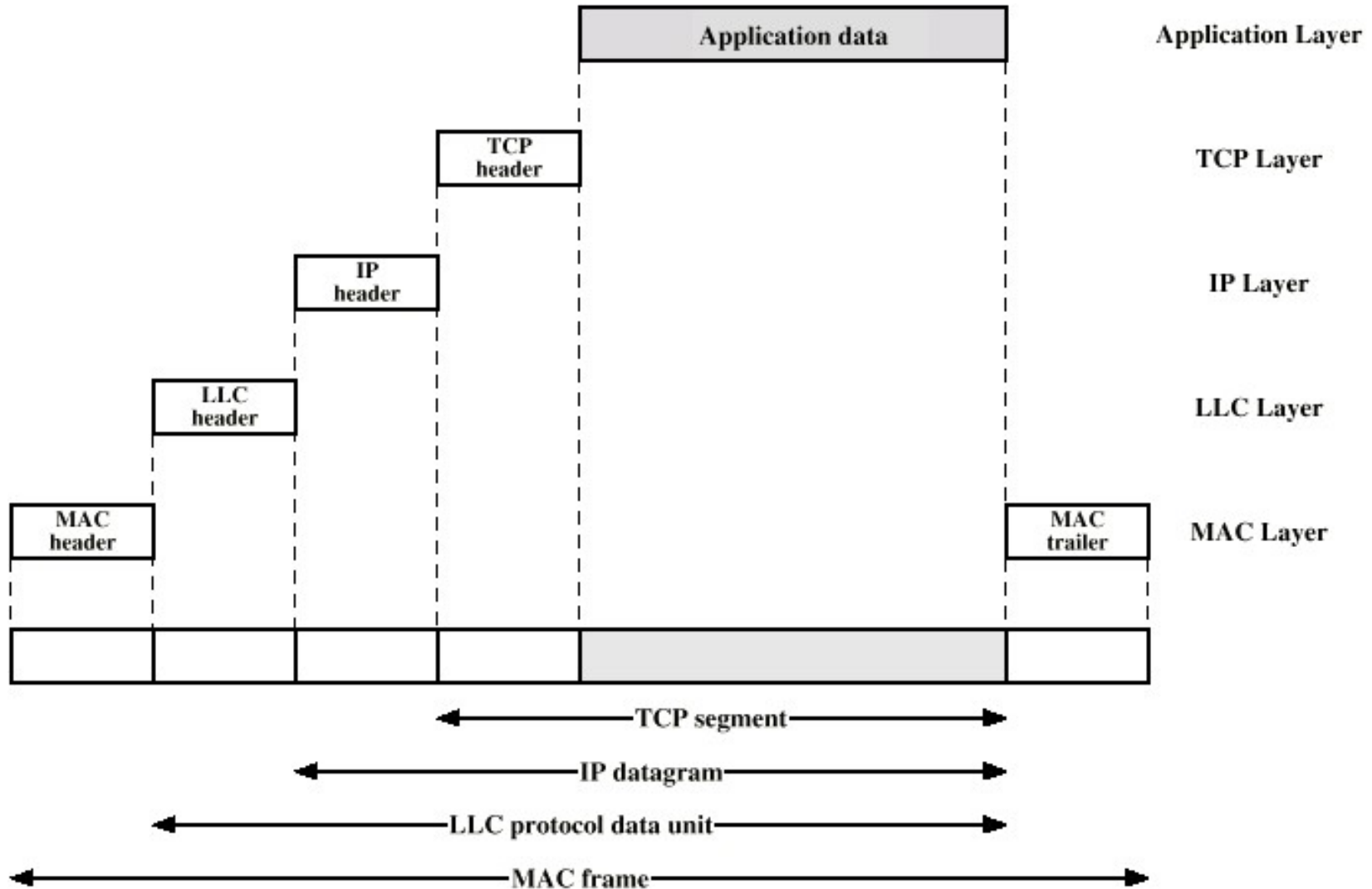

## Ring Topology

Repeaters joined by point to point links  
in closed loop

Receive data on one link and  
retransmit on another

Links unidirectional

Stations attached to repeaters

Data in frames

Circulate past all stations

Destination recognizes address and  
copies frame

Frame circulates back to source  
where it is removed

Media access control determines when  
station can insert frame

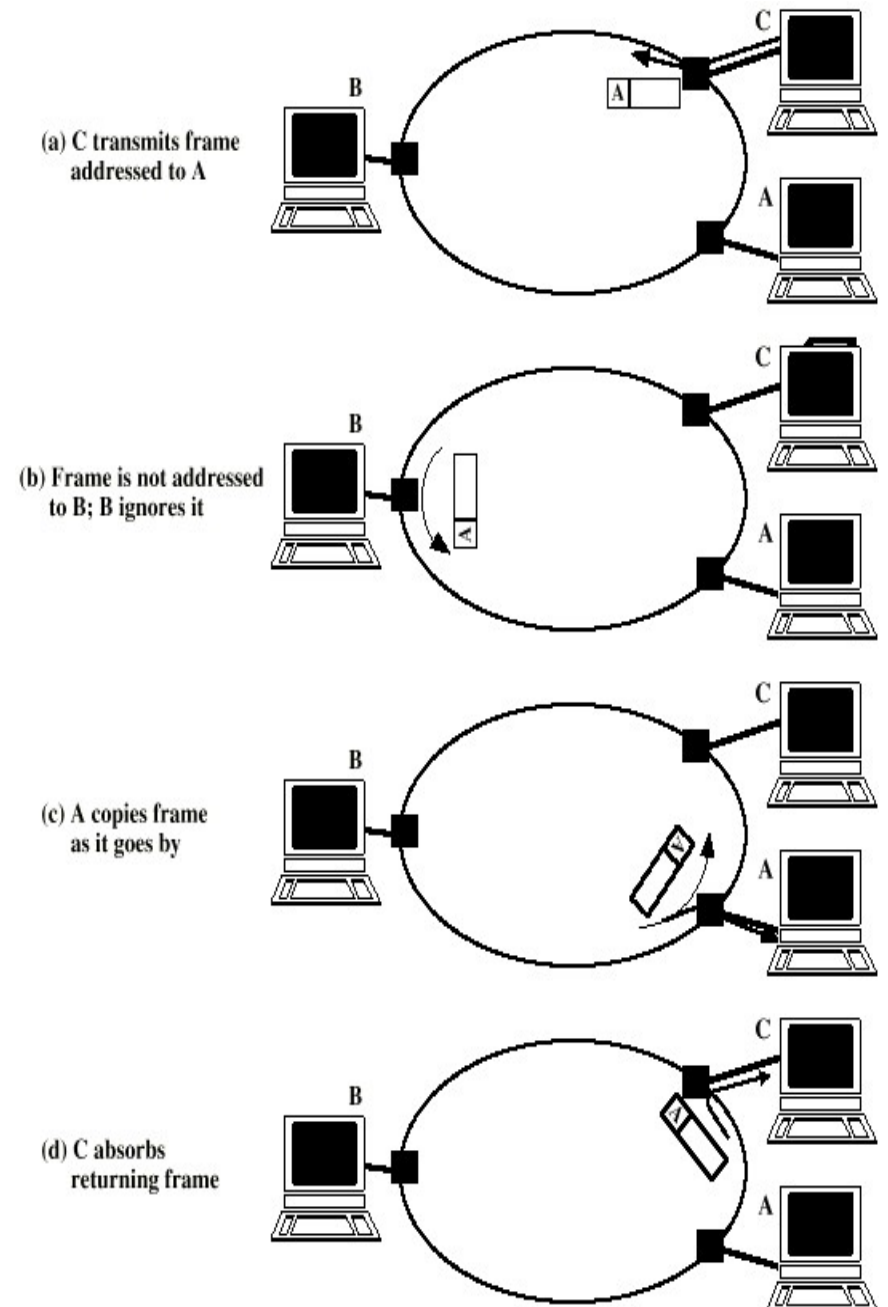



## **Advantages:**

Failure of a station does not affect ring transmission

Can cover a wider area (LANs, MANs, WANs)

## **Disadvantages**

Limited number of nodes/ring

Failure of repeater may cause failure of ring transmission

More complex operation to insert new nodes and to manage network (clock synchronization)

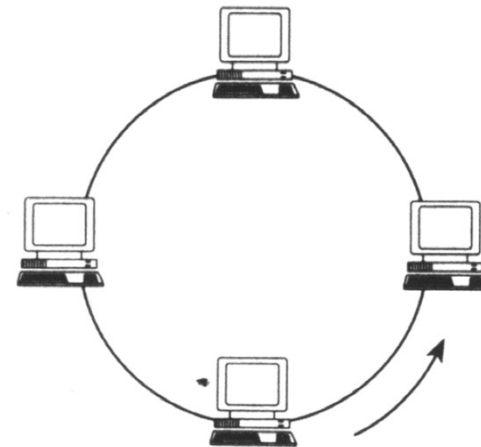

## **Star Topology**

Each station connected directly to central node

Usually via two point to point links

Central node can broadcast

Physical star, logical bus (one station transmits at a moment, all receive)

Central node can act as frame switch.

### **Advantages:**

Easy to add devices

Easy to extend topology (extended star, snow-flake)

Possible to use existing telephonic infrastructure

ATM – friendly

Less prone to problems with connecting devices

More security (central access point – the switch)

Flexibility for customer needs

## Disadvantages:

Central switch down => all network down

Local switch down => local network down

Wiring overhead (more ducts, cabinets, power supply)

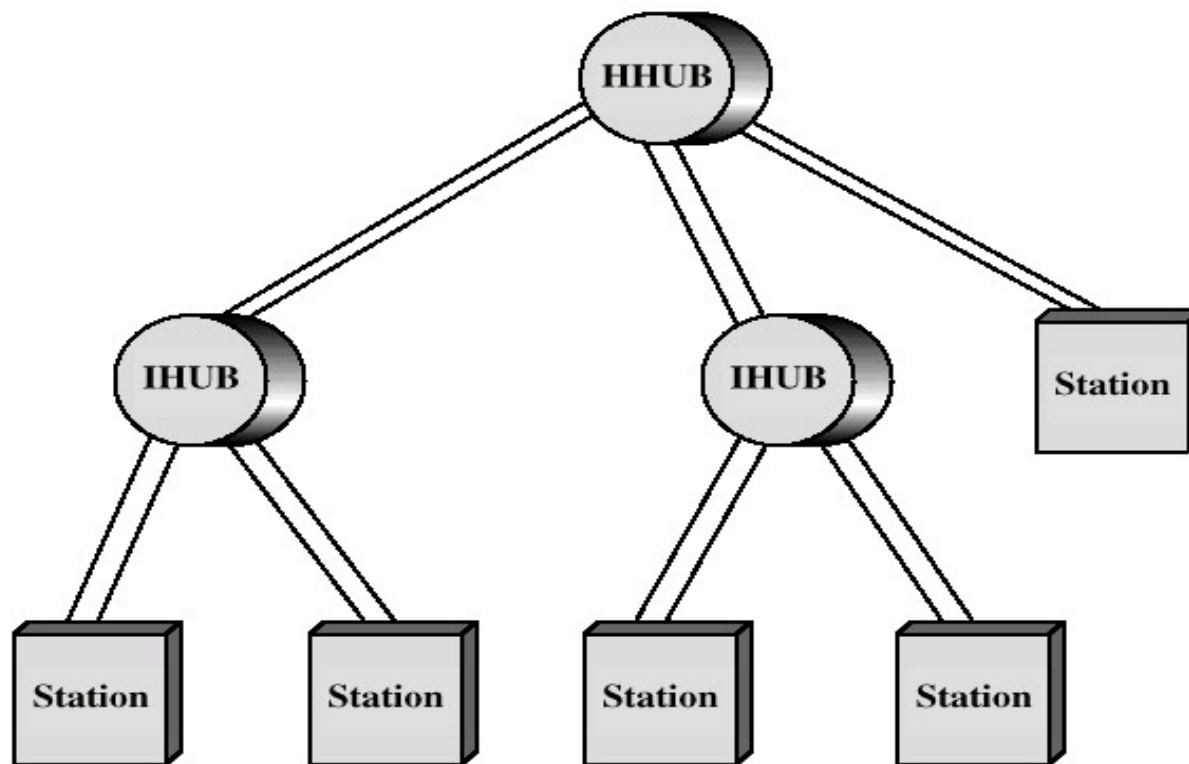

## **Medium Access Control**

Orderly & efficient use of the shared medium

**Centralized control** – one monitor (master) station

Greater control over network (priorities, guaranteed parameters, overrides)

Simple access logic at other stations

Avoids problems of co-ordination between stations

Single point of failure - monitor

Potential bottleneck – toward monitor, may reduce performance

**Distributed** – stations collectively perform control

-Synchronous

Specific capacity dedicated to connection (to each station) – less used in LANs – station needs are unpredictable

-Asynchronous (dynamic)

In response to (immediate) demand of each station

## **Asynchronous Control Approaches**

### **Round robin**

Each station in turn is given the opportunity to transmit (daisy-chain architecture)

Control: centralized (polling) or distributed.

Each station may decline to transmit or may transmit subject to some upper bound.

Good if many stations have data to transmit over extended period; less efficiency for small number of active stations (important polling overhead)

Less used for LAN control, used with terminal handling.

### **Reservation**

Allocated time for accessing the medium (time slots). Each station for transmitting will allocate future slots. In a way similar with synchronous TDM.

Good for stream traffic

Examples: token passing based protocols

## **Contention**

All station contend (compete) for gaining access, for an upper bounded time. Full distributed control.

Good for bursty traffic

Simple to implement

Efficient under moderate load

Tend to collapse under heavy load.

Examples: ALOHA (radio networks), CSMA (Ethernet)

## **MAC Frame Format**

MAC layer receives data from LLC layer; this is the payload or the LLC PDU

Additional fields:

MAC control

Destination MAC address

Source MAC address

CRC

MAC layer detects errors and discards frames

LLC optionally retransmits unsuccessful frames

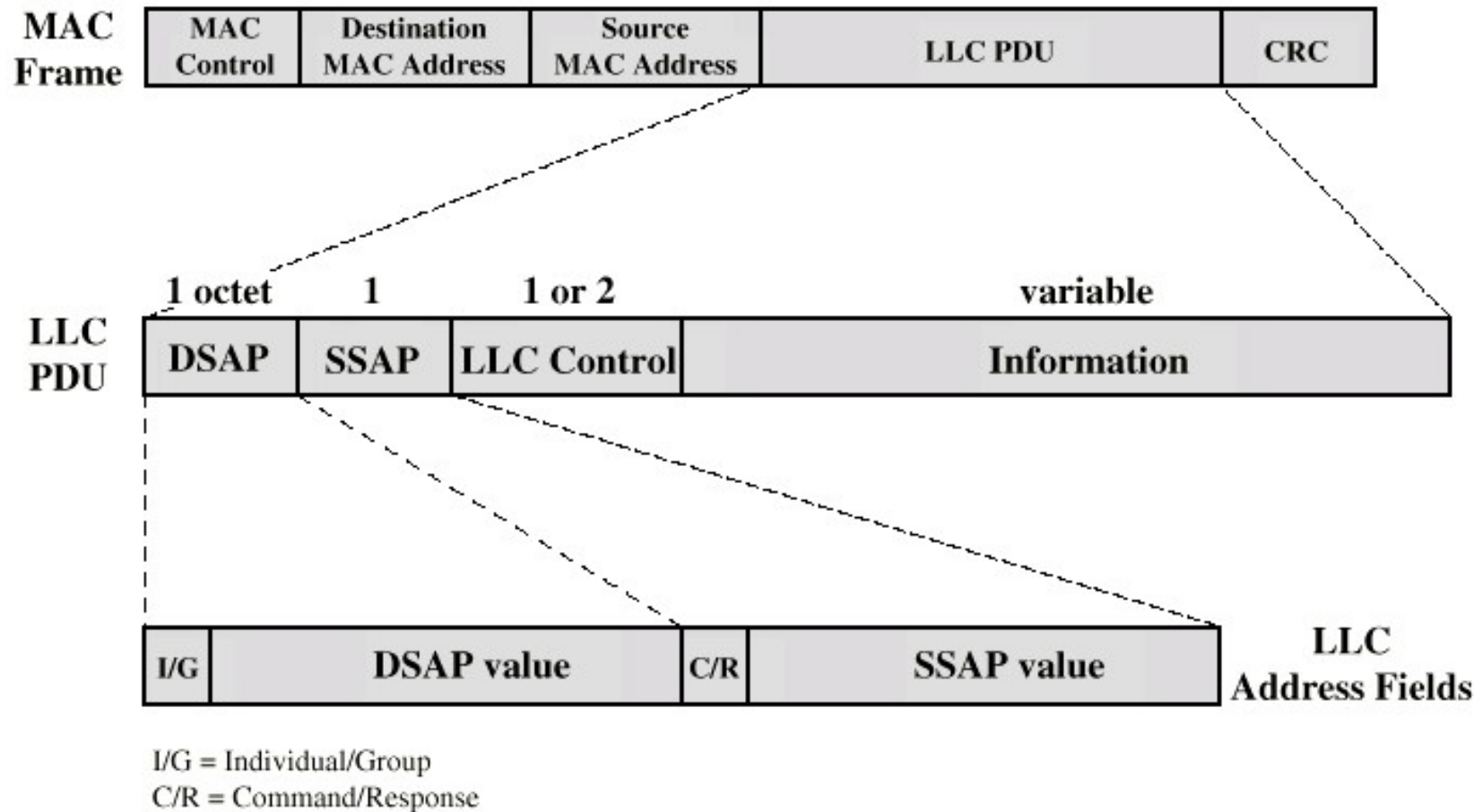

**SAP** - Service Access Point - a conceptual location at which one OSI layer can request the services of another OSI layer

## MAC Frame Format + LLC Frame Content



## **Logical Link Control**

Transmission of Data Link level PDUs between two stations having a direct data link (no switching node between)

Must support multiaccess, due to shared medium

Relieved of some link access details by the MAC layer

Addressing involves specifying source and destination LLC users (users: higher level protocol – network management)

LLC user addresses referred to as service access points (SAPs)

Allows connection multiplexing

### **LLC Services**

Addressing stations and controlling data exchange between SAPs (users)

Based on HDLC

LLC-1:Unacknowledged connectionless service (datagram style)

LLC-2:Connection mode service (similar to HDLC)

LLC-3:Acknowledged connectionless service (trade-off)

## Most used contention-based MAC techniques

**ALOHA**, first developed for packet radio networks (Univ. Hawaii)

Simplest protocol:

- When station has frame, it sends

- Station then listens (for a max round trip time, twice the transmission time between the most widely separated stations), plus small increment

- If ACK, fine. If not, retransmit

- If no ACK after repeated transmissions, give up

For correctness at receiver: use of frame check sequence (as in HDLC)

Each station: if frame OK and address matches receiver, send ACK

Frame may be damaged by noise or by another station transmitting at the same time (collision)

Any overlap of frames causes collision

Max. medium utilization 18%, due to the fact that increased load gives increased number of collisions.

## **Slotted ALOHA**

Conceived to improve efficiency

Time organized in uniform slots, equal to frame transmission time

Need central clock (or other sync mechanism)

Transmission begins at slot boundary

Frames either miss collision, or overlap totally

Max utilization 37%

## **CSMA (Carrier Sense Multiple Access)**

For 10Mbps LANs, usually the propagation time between stations is much less than frame transmission time; not true with 100 or 1000Mbps LANs – switched LANs

All stations know almost immediately that a transmission has started

CSMA algorithm based on following ideas:

Each station first listens for clear (idle, not busy) medium (carrier sense)

If medium idle, and has to transmit, will transmit immediate

*(implementation of the 1-persistent CSMA technique)*

If two stations start at the (approx.) same instant, collision of frames

Transmitter waits reasonable time (round trip, plus ACK contention)

No received ACK, collision occurred, so will retransmit

Max utilization depends on propagation time (medium length) and frame length (transmission time)

Longer frame and shorter propagation gives better utilization

### **CSMA/CD (CSMA / Collision Detection)**

With CSMA, collision occupies medium for the durations of implied transmissions

Remedy: stations listen while transmitting, detecting collision occurrence

If medium idle, transmit

If busy, listen for idle, then transmit

If collision detected, transmit short jamming signal, then cease transmission

After jam, wait random time then start again listening the medium

Binary exponential back-off waiting algorithm:

The time to wait  $t$ , for the  $n$ -th attempt, the value being randomly chosen in the interval  $0 < t < 2^k$ , where  $k = \min(n, 10)$ . The number of attempts is bounded (to 16).

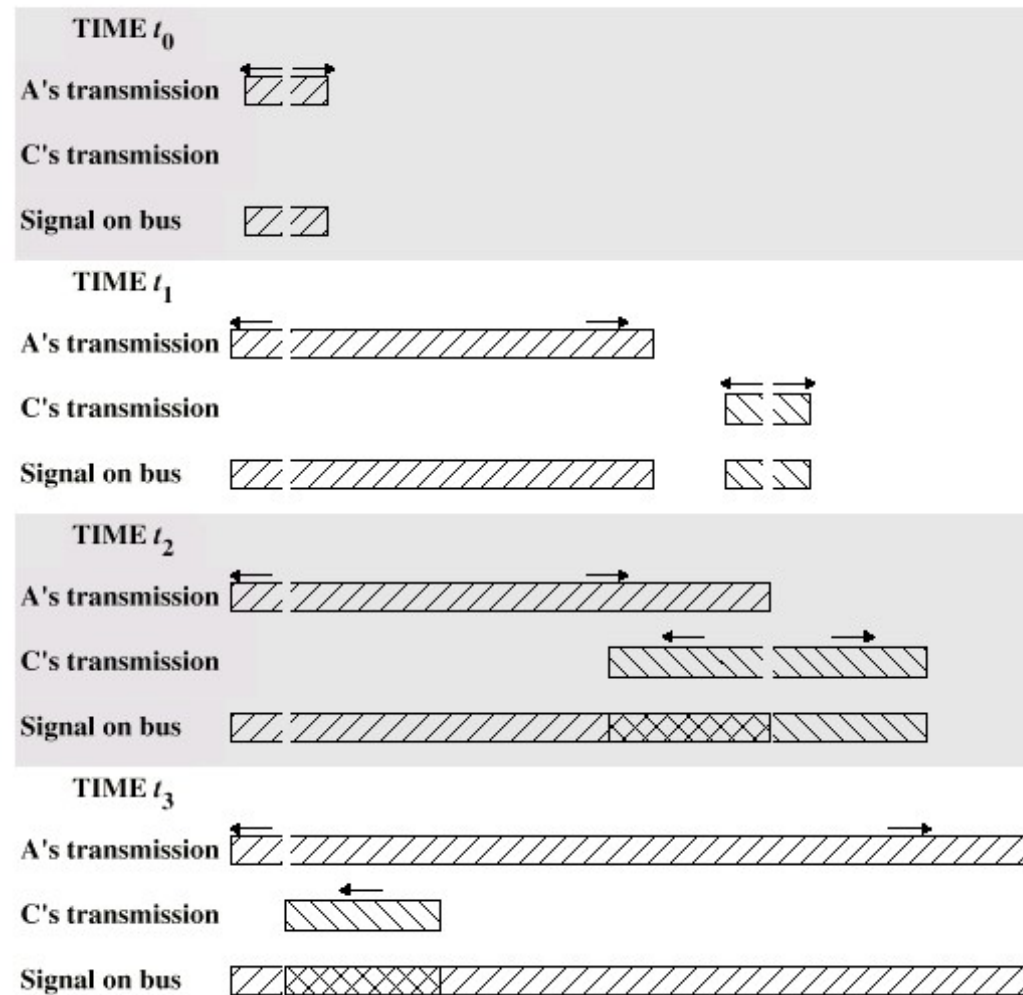
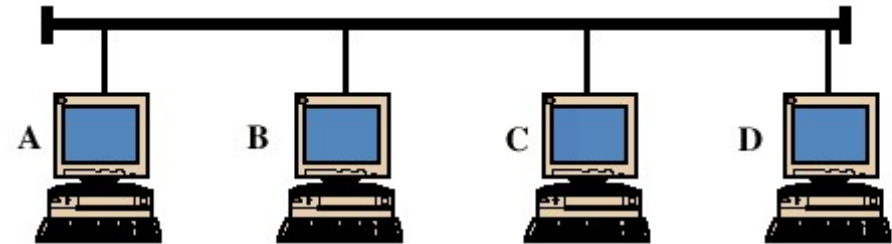

## Illustration of CSMA/CD algorithm

## **Token passing based protocols**

### **Token Ring**

#### MAC protocol

One (only) small frame (token) circulates when medium idle

Station waits for token

Changes one bit in token to make it start of frame SOF for data frame

Append rest of data frame

Frame makes round trip and is absorbed by transmitting station

Station then inserts new token when transmission has finished, and leading edge of returning frame arrives

Under light loads, some inefficiency

Under heavy loads, acts as round robin



SD = starting delimiter      DA = destination address      ED = ending delimiter  
 AC = access control      SA = source address      FS = frame status  
 FC = frame control      FCS = frame check sequence

(a) General Frame Format



(b) Token Frame Format



J, K = non-data bits      E = error-detected bit  
 I = intermediate frame bit

(c) Ending Delimiter Field



PPP = priority bits      M = monitor bit  
 T = token bit      RRR = reservation bits

(c) Access Control Field



A = Address recognized bit      rr = reserved  
 C = Frame copied bit

(e) Frame Status Field



FF = frame-type bits      ZZZZZZ = control bits

(d) Frame Control Field

## Token Ring MAC frame structure

## Token Ring Operation

After seizing the token, station A transmits a frame to station C

Station C copies the packet, inserts ACK

When packet back to A, it removes packet from the ring and releases token

When station C seizes token, sends packets for A and D stations

Each destination stations copy packets

When packet back to C, it purges the ring and releases token

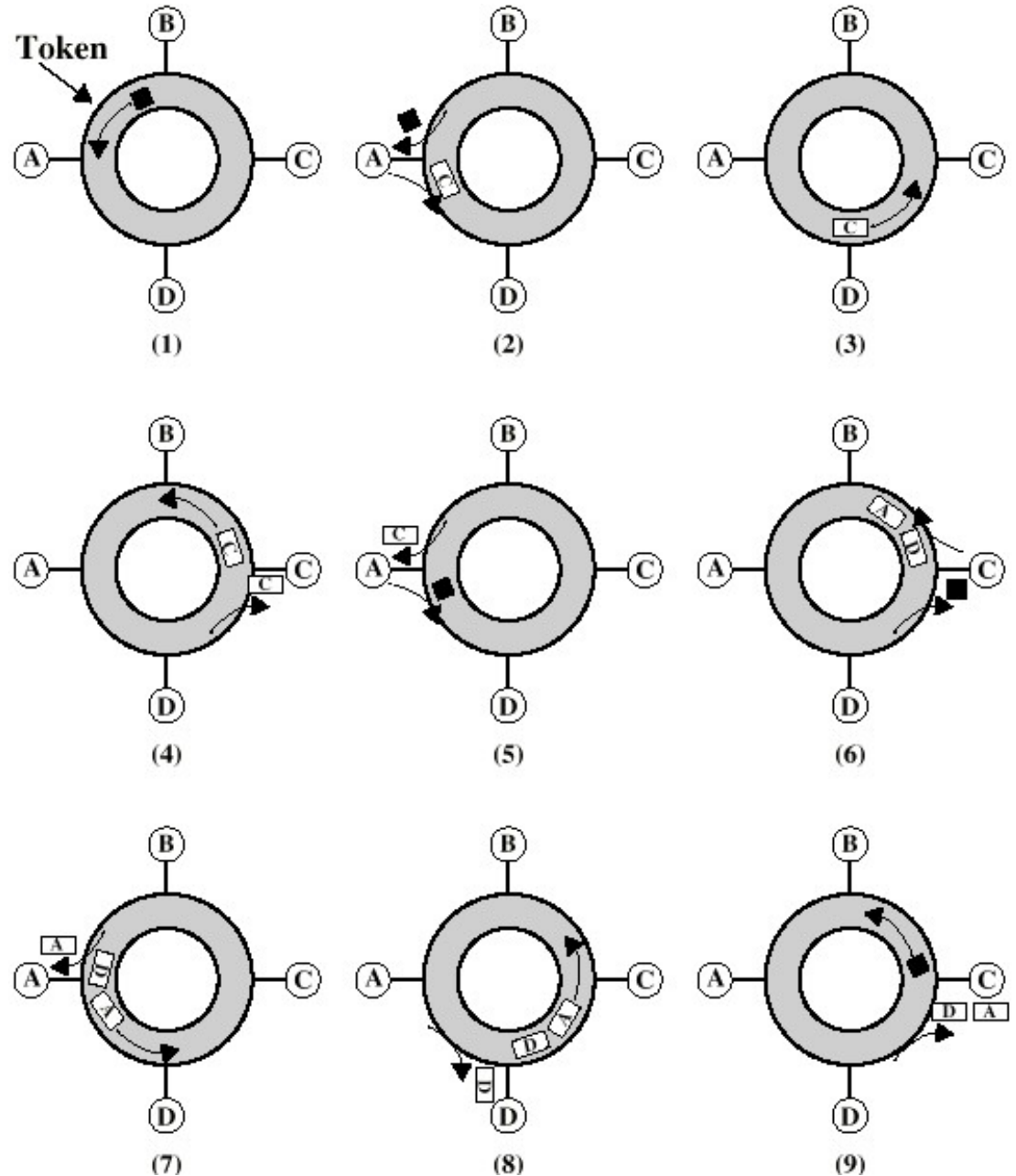



## Token Ring Operation (involving priorities scheme)

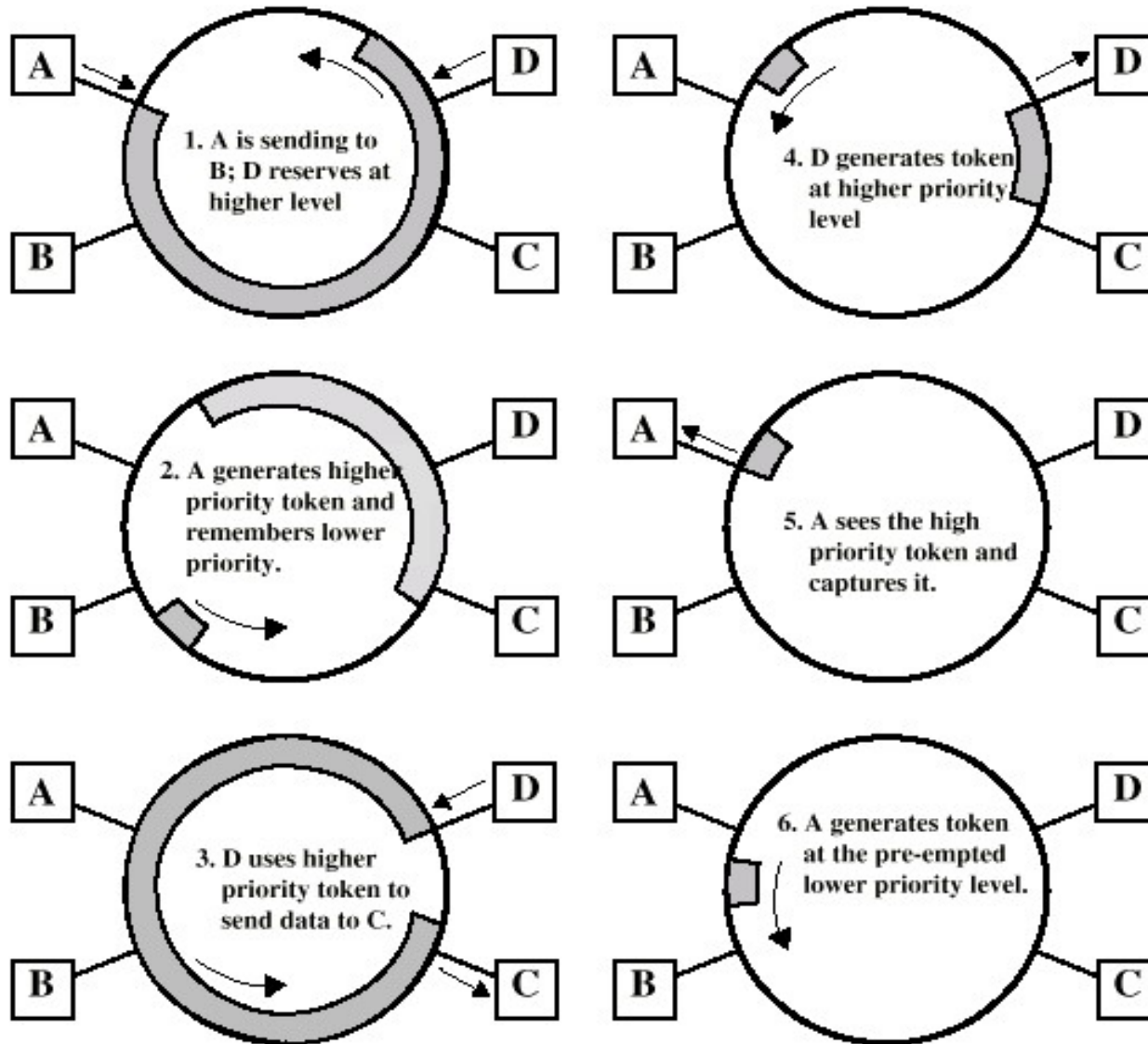

## Ring topology LANs

### IEEE 802.5 Token Ring

*Remember:*

Acts at 4Mbps, 16Mbps and (will) 100Mbps, using UTP, STP and FO

Differential Manchester encoding

Each station connected using a repeater, which introduces a delay when active!

Each repeater connects to two others via unidirectional transmission links

Single closed path

Data transferred bit by bit, from one repeater to the next

Each repeater introduces one bit delay

Repeater regenerates and retransmits each bit

Repeater performs data insertion, data reception, data removal

Packet removed by transmitter after one trip round ring

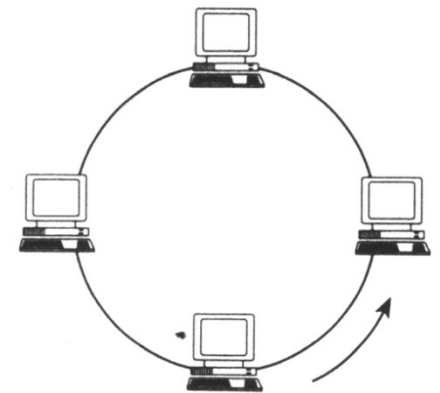

For the MAC level, *remember*:

One (only) small frame (token) circulates when medium idle

Station waits for token

Changes one bit in token to make it start of frame SOF for data frame

Append rest of data frame

Frame makes round trip and is absorbed by transmitting station

Station then inserts new token when transmission has finished, and leading edge of returning frame arrives; also allowed **early token release**

Network control – by the active **monitor**, chosen from a list of stand-by monitors

Quite complex MAC control, many ring management operations.



SD = starting delimiter      DA = destination address      ED = ending delimiter  
 AC = access control      SA = source address      FS = frame status  
 FC = frame control      FCS = frame check sequence

(a) General Frame Format



(b) Token Frame Format



J, K = non-data bits      E = error-detected bit  
 I = intermediate frame bit

(c) Ending Delimiter Field



PPP = priority bits      M = monitor bit  
 T = token bit      RRR = reservation bits

(c) Access Control Field



A = Address recognized bit      rr = reserved  
 C = Frame copied bit

(e) Frame Status Field

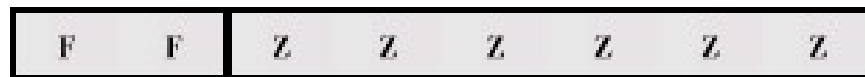

FF = frame-type bits      ZZZZZZ = control bits

(d) Frame Control Field

Repeater is in one of the following states:

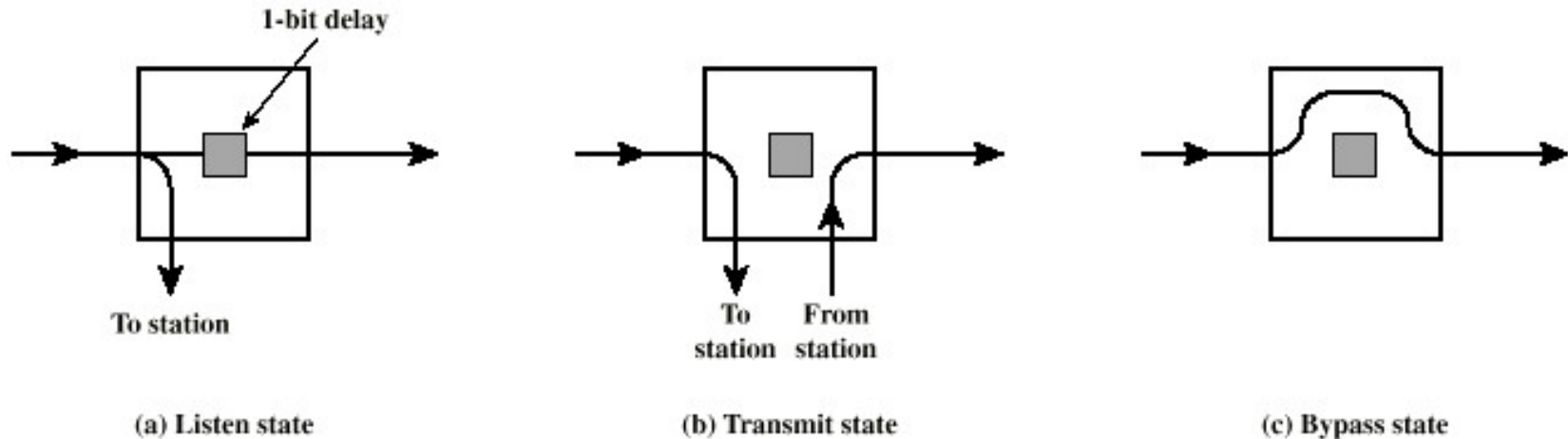

## Listen State Functions

Scan passing bit stream for pertinent patterns:

Address of attached station; if station is destination of the passing frame

Token permission to transmit

Copy incoming bit and send to attached station

Whilst forwarding each bit

Modify bit as it passes, e.g. the C bit, to indicate a packet has been copied (acts as ACK)

## **Transmit State Functions**

Station has data to put on ring

Repeater has permission to send

Repeater receives bits from station and puts them on ring

May receive incoming bits, from the ring, on incoming line

If ring bit length is shorter than transmitted packet length

Pass back to station for checking (ACK, by example)

May be more than one packet on ring (some control strategies allow)

Buffer bits for retransmission later

## **Bypass State**

Signals propagate past repeater with no delay (other than propagation delay)

Partial solution to reliability problem (station not in use)

Allows improved performance

Physical level problem: **Timing Jitter**

Clocking included with signal, using differential Manchester encoding

Clock recovered by repeaters, because:

To know when to sample the signal and recover frame bits

Use of clocking for data retransmission on the ring

Clock recovery deviates from 'original' midbit transmission randomly, due to

Noise during transmissions

Imperfections in receiving circuitry

Deviation of clock recovery is named **timing jitter**

Repeater data retransmissions obtained without distortion, but with random timing error

Cumulative effect is that the bit length varies

Timing jitter limits the number of repeaters on ring.

## **Solving Timing Jitter Limitations**

Two methods used in combination:

Repeater uses phase-locked loop (device using feedback, minimizing the deviation from one bit time to the next)

Use buffer at one or more repeaters

Programmed to hold a certain number of bits

Buffer expands and contracts to keep bit length of ring constant

Negative result: Significant increase in maximum ring size



## **Other Potential Ring Problems**

Break in any link disables network

Repeater failure disables network

Installation of new repeater to attach new station requires identification of two topologically adjacent repeaters (neighbour identification)

Timing jitter

Many error sources on data frames, but on token control frames

Methods of removing circulating packets required

With backup in case of errors

**Mostly solved with star-ring architecture!** See following DTR development.

## Star Ring Architecture

Feed all inter-repeater links to a single site

Use of a concentrator acting as a multi-port repeater

Provides central access to signal on every link

Easier to find faults

Can launch message into ring and see how far it gets (beacon frames)

Faulty segment can be disconnected and repaired later

New repeater can be added easily

Bypass relay can be moved to concentrator

Can lead to longer cable runs

Can connect multiple rings using bridges

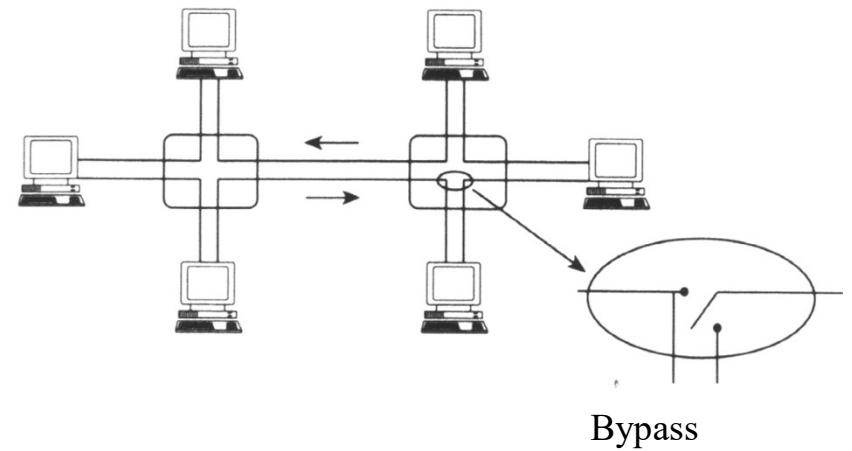

## **Dedicated Token Ring (DTR - recent development of 802.5 TR)**

Operates at 16, 32 and 100Mbps, backward compatibility with 802.5

**Switched Full Duplex Token Ring:** star shaped ring, using a central hub (multi-port repeater) which **acts as a switch** (multi-port bridge) => means that it doesn't act at bit level like an ordinary repeater, but as frame level repeater

Full duplex point to point links between switch and stations

- Use of dedicated links at 16Mbps

- Use of full duplex links at 32Mbps

No token passing used as MAC control

Flow-based access, or immediate access **TXI** (Transmit Immediate), e.g. communications can take place between a device and a switch at any time

## FDDI (Fiber Distributed Data Interface), ISO standard 9314

100Mbps network, used for LAN & MAN applications; fiber optic based (may use short UTP links); excellent for LAN backbones

Use of Token Ring MAC algorithm, with differences (*remember?*):

- Station seizes token by aborting token transmission
- Once token captured, one or more data frames transmitted
- New token released as soon as transmission finished (early token release in 802.5)
- Allows for asynchronous & synchronous frame transmissions
- Data & control coded as **symbols**, group of 4 bits carried as 5 bits by the medium (4B/5B)
  - provide necessary clock transitions for the receiver (0000<sub>2</sub> contains no transitions and that causes clocking problems for the receiver)
  - ensure at least two transitions per block of bits

Data (Hex)	(Binary )	4B5B code
0	0000	11110
1	0001	01001
2	0010	10100
3	0011	10101
4	0100	01010
5	0101	01011
6	0110	01110
7	0111	01111
8	1000	10010
9	1001	10011
A	1010	10110
B	1011	10111
C	1100	11010
D	1101	11011
E	1110	11100
F	1111	11101

## FDDI MAC Protocol

MAC protocol for FDDI (Fiber Distributed Data Interface): ss for 802.5, except:

Station seizes token by aborting token transmission

Once token captured, one or more data frames transmitted

New token released as soon as transmission finished (early token release in 802.5)



(a) General Frame Format



(b) Token Frame Format

SD = starting delimiter  
FC = frame control  
DA = destination address

SA = source address  
FCS = frame check sequence

ED = ending delimiter  
FS = frame status

## Example for FDDI Operation

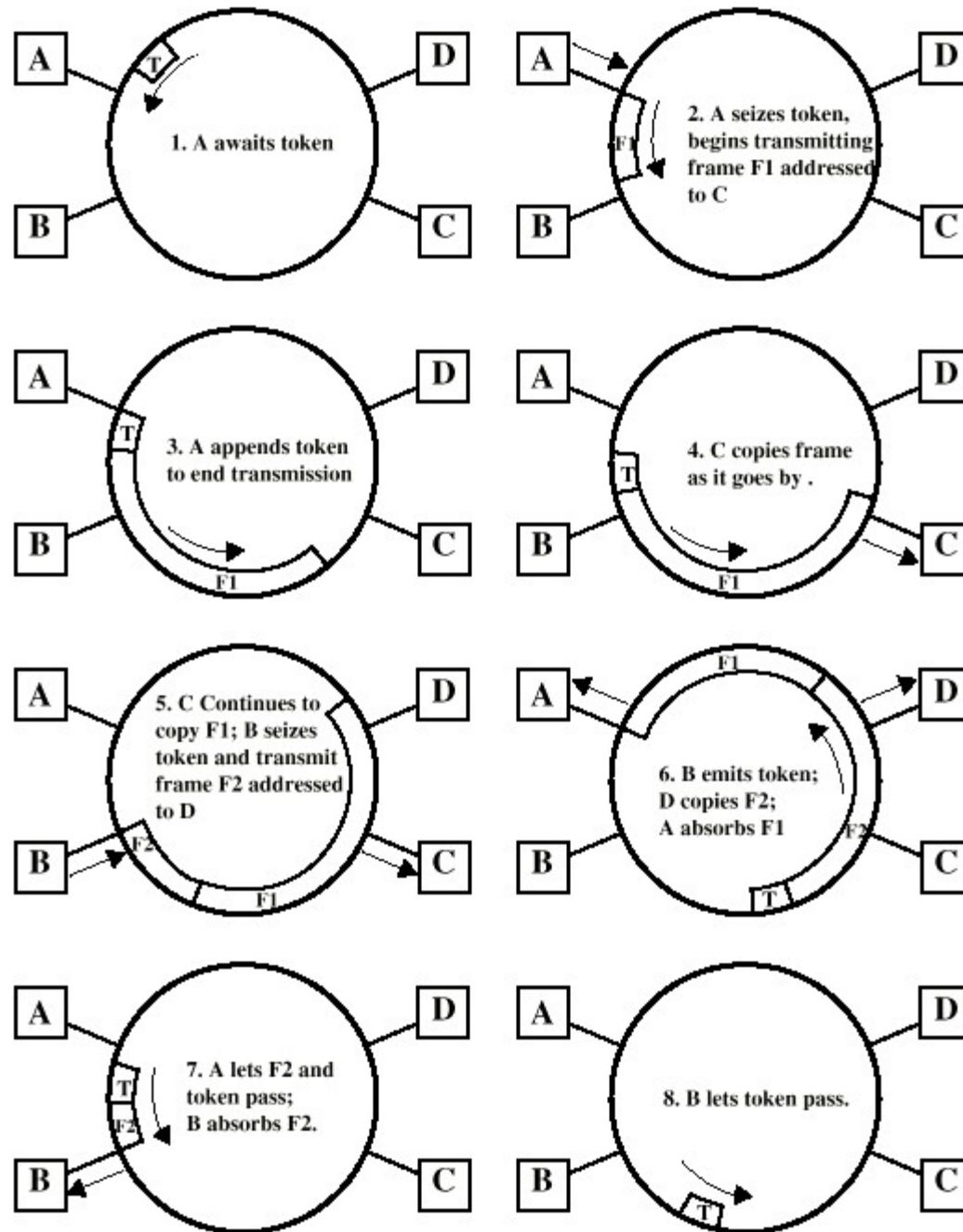

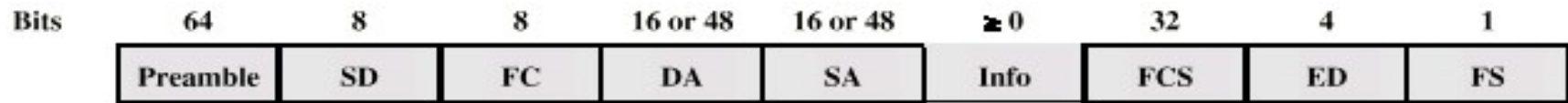

(a) General Frame Format



(b) Token Frame Format

SD = starting delimiter  
 FC = frame control  
 DA = destination address

SA = source address  
 FCS = frame check sequence

ED = ending delimiter  
 FS = frame status

## FDDI frame

Topology – two FO rings, with opposite flows:

- Primary ring
- Back-up ring

When crash, use of attach. unit bypass and ring merger => one flow

Three types of stations:

- DAS (Dual Attachment Station)
- DAC (Dual Attachment Concentrator)
- SAS (Single Attachment Station)

SAS connected only to the primary ring.  
TP used to connect SAS to DAC.

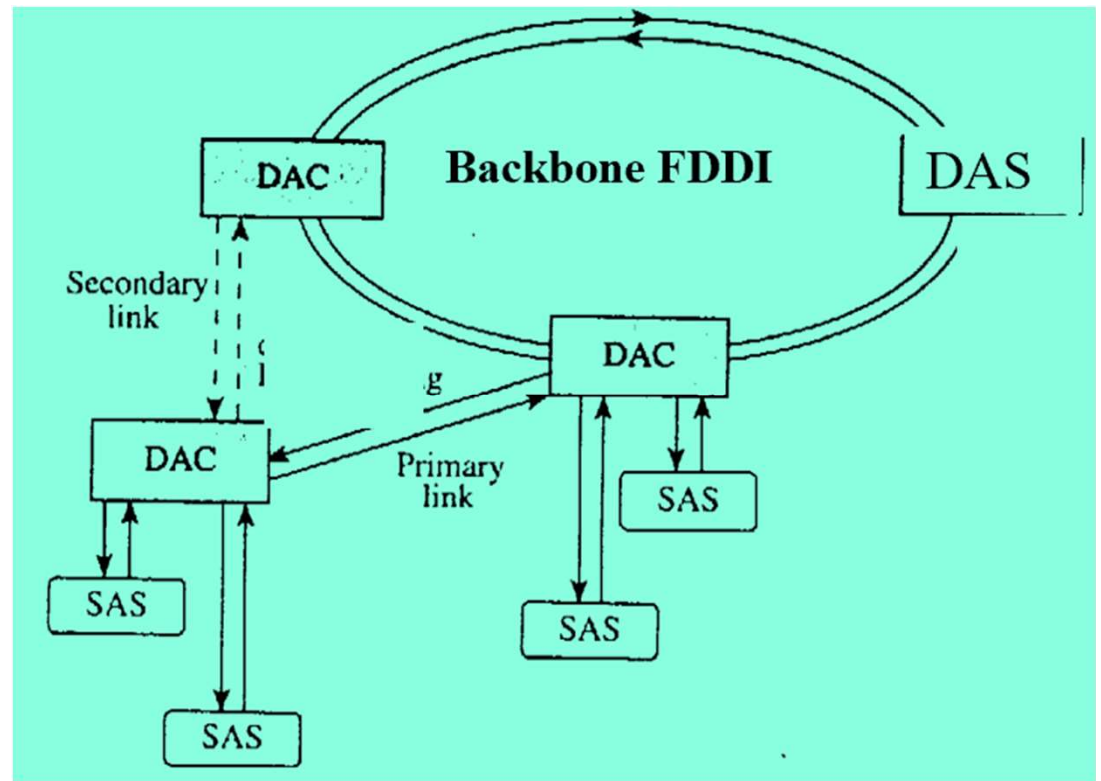



Architectural levels – one more level, **Station Management**, lowering complexity of MAC level (station initialisation & management, ring management: fault detection & isolation)

<b>MAC</b>	<b>SMT</b>
<b>PHY</b>	
<b>PMD</b>	

### **FDDI Physical Layer**

Extra to NRZ-NRZI coding, is used multi-level coding MLT-3, allowing lower influence of attenuation over data

Some usual parameters:

Medium	Optical Fiber	Twisted Pair
Data rate	100	100
Signaling	4B/5B/NRZI	MLT-3
Max repeaters	100	100
Between repeaters	2km	100m

## **Solved problem: Data Link Control Algorithms**

Consider the use of 1000 bit frames on a 1Mbps satellite channel with a 270ms delay.

What is the maximum link utilization for:

Stop-and-wait protocol?

Continuous flow control with a window size of 7?

But with a window of 127?

What about a window of 255?

**Bit time:  $1/10^6 = 10^{-6}$  sec = 1 $\mu$ sec**

**Frame time:  $1,000 \times 1\mu\text{sec} = 1$  ms.**

**Assuming no extra delay at the receiver, one bit echo will take 270ms for being received by the sender.**

**Continued on next slide**

**Assuming that all control information is under the above delay:**

**(Stop-and-wait): Total transmission time for a frame is: 1 (frame time) + 270 (receiving ACK delay) = 271ms. So effective utilization of the channel is  $1/271 = .3\%$ .**

**(Window of 7): Sender can send 7 messages (frames) in advance, without ACK, until an enforced wait. 7 frames transmitted in 7ms. There is a 270ms delay after first frame, for the ACK (or RR) of the first frame. Each ACK for following frames takes other 1ms. Thus 7 frames sent correctly in:  $7 + 270 = 277\text{ms}$ , so an utilization of :  $7/277 = 2.5\%$ .**

**(Window of 127): 127 frames transmitted every 397ms ( $127 + 270$ ); utilization of:  $127/397 = 40\%$ .**

**(Window of 255):  $255/(255+270) = 51\%$ .**

## **CSMA/CD LANs**

### **Solved problem:**

Considering building a CSMA/CD network running at 1Gbps over a 1km cable with no repeaters. The signal speed is 200,000km/s. What is the minimum frame size?

**Network transmission time:  $1 / 10^9 = 10^{-9}$  s.**

**For detecting eventual collision, frame transmission must last at least double the propagation time within that medium (round trip delay).**

**Propagation time:  $1 / 200,000 = 0.5 \cdot 10^{-5}$  s, so its double will be  $10^{-5}$  s.**

**Number of bits in a minimum valid frame:  $10^{-5} / 10^{-9} = 10,000$  bits.**

## **Token Ring LANs**

### **Solved problem:**

Considering a Token Ring network at a bit rate of 4Mbps, and a signal propagation speed of 200m/ $\mu$ sec, and each interfaces introducing a delay of one bit period, find the cable length equivalent with a total of 20 interfaces on that ring.

**One's interface delay = One bit period:  $1 / (4 \cdot 10^6) = 0.25 \cdot 10^{-6}$  sec = 250nsec.**

**20 interfaces delay:  $20 \cdot 250$ nsec = 5 $\mu$ sec.**

**Propagation speed: 200m/ $\mu$ sec, so for 5 $\mu$ sec the cable equivalence is 1,000m.**